



# NewHomeSource and Move New Homes platform **Consumer leads reporting**

**Version 4.1**  
Nov 2011

---

## Table of Contents

<b>Table of Contents</b> .....	<b>2</b>
<b>Introduction</b> .....	<b>3</b>
<b>Lead types, recipients and delivery</b> .....	<b>4</b>
Lead types .....	4
Lead recipients .....	4
Filename conventions for attached leads .....	4
Delivery schedule .....	5
<b>Plaintext format</b> .....	<b>6</b>
Template sections .....	6
Example .....	6
<b>Tab-separated (TSV) format</b> .....	<b>8</b>
A. Record header .....	8
B. Contact information.....	8
C. Qualifications .....	9
D. Property interest .....	9
E. Telemetry.....	9
<b>XML format</b> .....	<b>10</b>
<BHILeads/> Element .....	11
<Lead/> Element .....	11
<Contact/> Element .....	11
<Qualifications/> Element .....	11
<PropertyInterest/> Element .....	12
<Telemetry/> Element.....	13
<b>Change history</b> .....	<b>18</b>

---

## Introduction

Consumer interest in new-home sales properties is gathered by Builder Homesite through Builders Digital Experience (BDX) and its network of related sites. With their consent, information about active home-buying consumers is distributed as sales leads to participating home builders via email. Follow-up may then be managed by the builder via their standard sales processes.

At the time of this writing, three distinct formats are used to distribute NHS consumer leads. These formats may be sent concurrently (the same lead data is sent within each):

- **plaintext format**, as text content within the body of the email. This is intended as a *human-readable format*, which can be readily distributed within builders' organizations as email, or by print or fax.
- **tab-separated values (TSV) format**, in the form of a text file document (.txt) attached to the email message. This file is a *machine-readable format*, intended for import into database-oriented systems.
- **Extensible Markup Language (XML) format**, in the form of an XML instance document (.xml) attached to the corporate copy of leads. This file is a *machine-readable format*, intended for import into database-oriented systems. **Note: XML lead format will only be delivered to the builder's Corporate Reporting Recipient.**

This document describes these lead reporting formats, with examples where possible.

---

## Lead types, recipients and delivery

---

### Lead types

Sales leads obtained through the BDX network are generally classified based on the process used by the consumer to search and select properties of interest.

Following are the categories of BDX sales leads and their bases of qualification.

Lead type	Definition
<b>Rec. Community</b>	Consumer has expressed interest in home offerings for a particular metro-area market within a certain price range. Optionally, the consumer may also have indicated a preference of builder, city location, or have responded to a builder-targeted marketing campaign.  <i>Based on this information, BHI has recommended this community as a match for the consumer's request.</i>
<b>Community</b>	Consumer has expressed interest in a specific new-home community or subdivision.
<b>Home</b>	Consumer has expressed interest in a particular plan, model or spec home within a specified community. <i>This is the most specific type of sales lead.</i>
<b>BuildOnYourLot</b>	Consumer has expressed interest in a Build On Your Lot program within a specified market area.

---

### Lead recipients

BDX consumer sales leads are generally routed by email. A consumer request for information will be routed to one of these recipients based on your setup:

- **Builder Default lead recipient** (*division*)
- **Subdivision lead recipient** (*community/local sales agent*)

If no Subdivision recipient is specified, leads will be delivered to the Builder Default recipient.

**Corporate Reporting Recipient.** This is a special recipient which receives *copies* of all sales leads which were distributed to multiple Builder and Subdivision recipients for your entire organization. Note: The XML lead format is only available for this recipient; XML cannot be delivered to Builder Default or Subdivision recipients.

In addition – unlike Builder and Subdivision recipients – the Corporate Reporting address can be specified as an FTP account<sup>1</sup>, to which machine-readable TSV lead files or XML lead files will be uploaded by BHI. (If so specified, FTP uploads are sent in place of email messages.)

---

### Filename conventions for attached leads

TSV/XML file attachments will be named according to the following conventions:

**English** – leads generated from English-language sites e.g. NewHomeSource.com:

leads\_ccyymmddmmss\_uniquenumber.txt (TSV format)

leads\_ccyymmddmmss\_uniquenumber.xml (XML format)

---

<sup>1</sup> Contact your BHI representative to setup an FTP account for this purpose.  
BDX Confidential

**Spanish** – leads generated from Spanish-language sites e.g. CasasNuevasAqui.com:

Esleads\_ccyymmddmmss\_uniquenumber.txt (TSV format)

Esleads\_ccyymmddmmss\_uniquenumber.xml (XML format)

*where*

ccyymmdd = system date

mmss = system time in minutes/seconds

uniquenumber = system generated unique number.

---

## **Delivery schedule**

At the time of writing, this delivery schedule for consumer lead requests is in effect:

*Daytime hours, 7am-9pm CT:* BHI processes and distributes leads approximately in “real time”.  
(Note: Leads are subject to BHI processing, which may add a few minutes to the delivery time depending on system load.)

*Overnight hours, 9pm-7am CT:* BHI distributes leads every two hours.

---

## Plaintext format

Consumer leads in the plaintext format are sent within the body of a lead email, per the template example below.

Spaces and newline markers are used to “format” the lines within the message so the information is easy to read – for best results, set your email client to display these messages in a fixed-width typeface such as Courier.

---

### Template sections

These groupings of consumer data are referenced by the example below.

- A. Email header.** The total number of leads contained within this email is in parentheses on the Subject line.
- B. Lead separator and summary.** An at-a-glance summary with the consumer’s name, lead type, market area of interest, and preferred move-in date (if known).
- C. Record header.** Marketing channel and lead type.
- D. Property interest.** The consumer’s area of interest, along with any relevant property data.
- E. Contact information.** Profiled email, address and telephone numbers (if given).
- F. Qualifications.** Consumer-selected information intended to help an agent service this request. Comments and questions about the interested property are located here.
- G. Comments and lead details.** Consumer’s comments or questions. If the lead was generated via a Campaign, or from a listing with a Promotion, this is also noted here.

Refer to the TSV format in the following section for specific data values.

Note that lead records will contain varying amounts of data, depending on the type of lead request, and customer participation in answering optional questions. Where information is not supplied or is null, its corresponding row is generally removed from the plaintext output.

---

### Example

Following is a sample email message containing two leads (of Home and Rec. Community type) in plaintext format.

**A** From: leads@theBDX.com [mailto:leads@theBDX.com]  
 To: salesagent@happyhomes.com  
 Subject: Sales leads from BDX (2)  
 Reply-To: support@theBDX.com

**B** =====

**C** 1. Doe, Jane (Move-in: 4/2002)

**C** Source: BDX  
 Lead type: Home

**D** State/Market: MD:Washington DC  
 Builder: Happy Homes - Mid-Atlantic  
 Community: #ATMNR Autumn Ridge  
 Master Comm: Pleasant Valley  
 Plan: #CS105A The Herkimer  
 Spec/Address: #SP-2541 105 Alden Lane  
 Options: Extra Bedroom 1  
 Price: \$227,990

**E** Name: Ms. Jane Doe  
 Email: janedoe@devnull.com  
 Address: 123 Any Place #145  
 Burnt Corn, AL 36431  
 USA  
 Telephone: (251) 555-1234

**F** Preferred price range: 200000 - 249000  
 Financing preference: Interested in builder financing  
 Time spent in market: 2 months or more  
 Reason in market: Relocating

**G** Comments/Questions: Do you have separate garage plans?  
 Lead details: Campaign: Happy Homes- Tradeup article

=====  
 2. Sumner, Gordon

Source: BDX  
 Lead type: Rec. Community  
 State/Market: MD/Washington DC  
 Builder: Happy Homes - Mid-Atlantic  
 Community: #42 Estates  
 Master Comm: Eastern Woods

Name: Gordon Sumner  
 Email: sumner@boo.com  
 Address: 42 Runnin Place  
 Oxon Hill, MD 20745

Preferred price range: 300000 - 349000

## Tab-separated (TSV) format

Consumer lead requests in the TSV format are sent according to the following column-order template.

This information is sent within a text file (.txt extension), from which it may be parsed into a database, or opened with a spreadsheet such as Microsoft Excel. Columns will be separated by a tab (ASCII 09) delimiter. Rows (lead records) will be separated by CR/LF (ASCII 13/10). *Important:* To assist importing this information into lead-management or sales-automation tools, header rows are not included.

Note that not all columns will be filled for a given record:

- Lead records will have varying amounts of data based on the *lead type*:  
e.g. Community leads – where the consumer is interested in a particular subdivision, but has not indicated a preference for a specific home – do not contain Plan/Spec info.
- Additionally, some consumer data is *optional*, and therefore may not be collected from some consumers.

Columns are grouped into related sections below for easy reference. The column number (beneath “#”, below) indicates the absolute column position for a given data element.

### A. Record header

Lead source and type.

#	Column key	Notes
1	<b>Source</b>	Channel from which lead was generated, e.g. BDX or CasasNuevasAqui (Spanish)
2	<b>LeadType</b>	Type of request. - Rec. Community - Community - Home - BuildOnYourLot

### B. Contact information

Profiled contact information sent by this consumer.

#	Column key	Notes
3	<b>Title</b>	Mr., Mrs., Ms., etc.
4	<b>FirstName</b>	First (given) name.
5	<b>LastName</b>	Last name (surname).
6	<b>Email</b>	Email address.
7	<b>Phone</b>	Telephone number.
8	<b>Unused</b>	<i>Not populated (empty column).</i>
9	<b>Unused</b>	<i>Not populated (empty column).</i>
10	<b>StreetAddress</b>	Mailing address: Street.
11	<b>City</b>	Mailing address: City name.
12	<b>State</b>	Mailing address: State (two-letter USPS abbreviation).
13	<b>PostalCode</b>	Mailing address: ZIP code.
14	<b>Country</b>	Mailing address: Country (defaults to USA at this time).



**C. Qualifications**

Consumer-selected information which may assist agents in servicing lead requests.

#	Column key	Notes
15	<b>PrefPriceLow</b>	Preferred minimum home price (low end of range).
16	<b>PrefPriceHigh</b>	Preferred maximum home price (high end of range).
17	<b>Financing</b>	Financing preference/status: <ul style="list-style-type: none"> <li>- Interested in builder financing</li> <li>- Already selected a lender</li> <li>- Will arrange own financing</li> <li>- Undecided</li> </ul>
18	<b>Unused</b>	<i>Not populated (empty column).</i>
19	<b>ReasonsForBuying</b>	Main reason consumer is in the market: <ul style="list-style-type: none"> <li>- Relocating</li> <li>- Ready to stop renting</li> <li>- Growing family</li> <li>- Empty nest</li> <li>- Seeking luxury housing</li> <li>- Retiring / senior</li> <li>- Opportunity to build the way I want it</li> </ul>
20	<b>MoveInDate</b>	Preferred move-in-date
21	<b>Unused</b>	<i>Not populated (empty column).</i>
22	<b>Comments</b>	Free response to agent: open questions or comments about selected properties

**D. Property interest**

Home/community listing for which additional information is being requested.

#	Column key	Notes
23	<b>StateName</b>	State in which desired properties are located.
24	<b>MarketName</b>	Market area in which desired properties are located.
25	<b>BuilderNumber</b>	Unique ID of builder (or builder division) to which this lead is being sent.
26	<b>BuilderName</b>	Name of builder (or builder division).
27	<b>CommunityNumber</b>	Unique ID of subdivision.
28	<b>CommunityName</b>	Name of subdivision.
29	<b>MasterCommunity</b>	Name of "parent" master-planned community, if any.
30	<b>PlanNumber</b>	ID of home plan.
31	<b>PlanName</b>	Name of home plan.
32	<b>Options</b>	List of preferred Plan Options, as selected by consumer. (Relevant only for homes with Options data as defined by BHI – see XML Data Integration Guide.)
33	<b>SpecNumber</b>	ID of spec home.
34	<b>SpecAddress</b>	Street address (for spec home).
35	<b>Price</b>	Plan or Spec home price, as shown to consumer.

**E. Telemetry**

Extended service information.

#	Column key	Notes
36	<b>Unused</b>	<i>Not populated (empty column).</i>

#	Column key	Notes
37	<b>Unused</b>	<i>Not populated (empty column).</i>
38	<b>CountElements</b>	Checksum element: Integer representing number of elements containing non-null data for this record.
39	<b>LeadDetails</b>	For leads obtained via targeted promotions: Name of the Builder Campaign or Builder Promotion which this listing is tied to.

## XML format

Consumer lead requests in the XML format are sent according to the following XML Schema notation (XSD).

The BDx XML lead file uses UTF-8 encoding. For more information, please refer to the NewHomeSource and Move New Homes XML Data Integration Guide, and other related XML documents.

The following is an overview of the BDx XML Lead Schema:

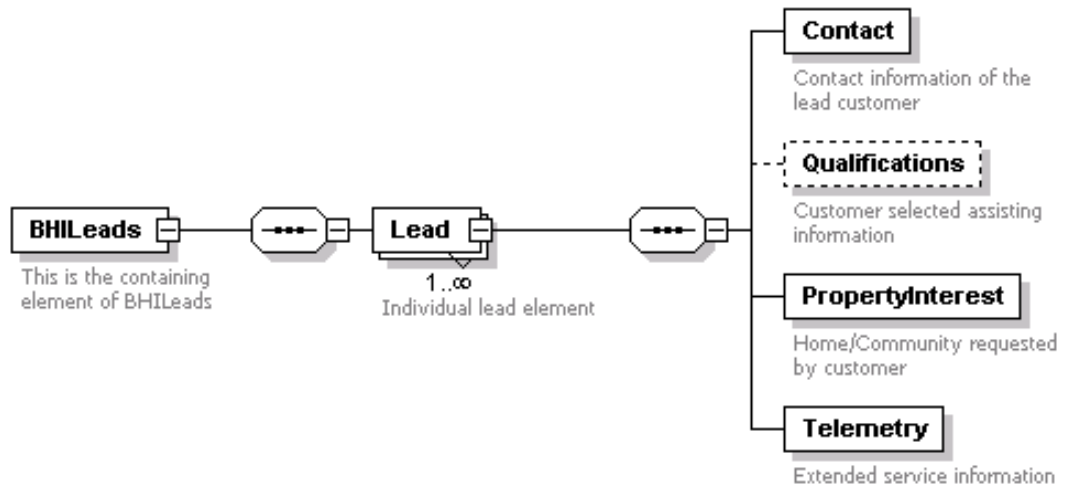

- **BHILeads** is the root element of the schema.
- **Lead** is a grouping element for all information related to an individual lead. Each lead contains four elements related to the TSV sections:
  - **Contact**
  - **Qualifications**
  - **PropertyInterest**
  - **Telemetry**

The informative data within a lead are structured as attributes of these four elements. (Lead content is sent as attributes rather than child elements to reduce text space and facilitate transportation and processing.)

Please note that the amount of information contained within a given lead will vary depending on the lead type and the consumer’s willingness to provide personal information. If the information for an attribute is not available (NULL) then the attribute will not be sent.

Following is a detailed description of the BDx XML Lead Schema. Refer to the Appendix for the full schema (XSD).

**<BHILeads/> Element**

Element	Attribute	Notes
BHILeads		Root element of BDX lead document.

**<Lead/> Element**

**<Lead  
Source="" LeadType=""/>**

Element	Attribute	Notes
Lead		This is a grouping element of all leads. It is a required element. Each XML lead document has to have at least one lead in it.
	Source	It is of string data type; and it contains the information of where these leads were generated. This attribute is required.
	LeadType	This is a required attribute. LeadType can be the following values: Rec. Community, Community, Home, BuildOnYourLot.

**<Contact/> Element**

**<Contact  
Title="" FirstName="" LastName="" Email="" Phone="" StreetAddress="" City=""  
State="" PostalCode="" Country=""/>**

Element	Attribute	Notes
Contact		The Contact element contains contact information of a lead customer. It has ten attributes. The contact element is required, but all the attributes are optional. All the attributes are of the data type: string.
	Title	Optional, String. Lead customer title, such as Mr., Ms., ...
	FirstName	Optional, String. First name of lead customer
	LastName	Optional, String. Last name of lead customer
	Email	Optional, String. Email Address provided by lead customer
	Phone	Optional. Phone number of the lead customer, it should include area code and extension, if applicable, in free text format
	StreetAddress	Optional. Customer mailing address, including street number and street name
	City	Optional. City name of the customer lives
	State	Optional. State name of the customer lives
	PostalCode	Optional. Mailing zip code of the customer address
	Country	Default to USA

**<Qualifications/> Element**

**<Qualifications**

**LeadType="" PrefPriceLow="0" PrefPriceHigh="0" Financing="" ReasonsForBuying="" MoveInDate="" Comments=""/>**

Element	Attribute	Notes
Qualifications		This element is optional. The attributes under this element are the customer selected values to guide the property search and to better qualify the generated leads
	PrefPriceLow	Optional. Integer data type. The preferred minimum property price.
	PrefPriceHigh	Optional. Integer data type. The preferred maximum property price.
	Financing	Optional. Financing preference/status. It can be selected in the following options: Interested in builder financing, Already selected a lender, Will arrange own financing, Undecided. (BHI reserves the right to change the list as necessary)
	ReasonsForBuying	Optional. Main reasons a consumer is in the market: Relocating, Ready to stop renting, Growing family, Empty nest, Seeking luxury housing, Retiring / senior, Opportunity to build the way I want it. (BHI reserves the right to change the list as necessary.)
	MoveInDate	Optional. The date that the customer wishes to move into the new property.
	Comments	Optional. Any comments the customer wishes to make about anything, in free text format.

**<PropertyInterest/> Element**

**<PropertyInterest**

**StateName="" MarketName="" BuilderNumber="" BuilderName="" CommunityNumber="" CommunityName="" MasterCommunity="" PlanNumber="" PlanName="" Options="" SpecNumber="" SpecAddress="" Price=""/>**

Element	Attribute	Notes
PropertyInterest		This element is required. It is the property the lead customer is interested in. It has 12 attributes. Because the property can be either a home (plan/spec) or a community, many attributes are optional.
	StateName	Required. The name of the state that the property resides
	MarketName	Required. The market area that the requested property is in.
	BuilderNumber	Optional. A unique ID that a builder/division uses to identify itself.
	BuilderName	Required. The name of the builder/division that puts the property on market.

Element	Attribute	Notes
	CommunityNumber	Optional. A unique ID that uniquely identify a builder community/subdivision within a builder/division. This is the community number supplied by the builder to BDX.
	CommunityName	Optional. The name of the subdivision that the interested property resides.
	MasterCommunity	Optional. Name of the Parent community.
	PlanNumber	Optional. A unique ID a division uses to identify its Plan.
	PlanName	Optional. The name of the interested Plan.
	SpecNumber	Optional. A unique ID that a constructed home is identified by its builder.
	SpecAddress	Optional. The address of a constructed home.
	Price	Optional. The price of the interested property.

### <Telemetry/> Element

<Telemetry  
CountElements="0" LeadDetails=""/>

Element	Attribute	Notes
Telemetry		This element is required. It provides some extended services.
	CountElements	Required. Checksum element: Integer representing number of non-null data values for this particular lead.
	LeadDetails	For leads obtained via targeted promotions: Name of the Builder Campaign or Builder Promotion which this listing is tied to.

Here is a sample XML lead file which is compatible with the BDX XML Lead Schema.

```
<?xml version="1.0" encoding="UTF-8"?>
<BHILeads>
  <Lead Source="BDX" LeadType="Rec. Community">
    <Contact Title="Mr." FirstName="John" LastName="Doe" Email="JohnDoe@abc.com" Phone="512-456-8493" StreetAddress="6666 Main Street" City="Austin" State="TX" PostalCode="78759" Country="USA"/>
    <Qualifications PrefPriceLow="200000" PrefPriceHigh="500000" Financing="Interested in builder financing" ReasonsForBuying="Relocating" MoveInDate="2003-9-9" Comments="Need info."/>
    <PropertyInterest StateName="TX" MarketName="Austin" BuilderNumber="343-dsr" BuilderName="Holiday Homes" CommunityNumber="skf345" CommunityName="Circle C" MasterCommunity="South Austin"/>
    <Telemetry CountElements="25" LeadDetails="Special Promotion"/>
  </Lead>
  <Lead Source="BDX" LeadType="Home">
    <Contact Title="Mr." FirstName="David" LastName="Smith" Email="David_Smith@Yahoo.com" Phone="512-234-3523" StreetAddress="6886 Snow Street" City="Austin" State="TX" PostalCode="78759" Country="USA"/>
    <Qualifications PrefPriceLow="160000" PrefPriceHigh="680000" Financing="Interested in builder financing" ReasonsForBuying=" Seeking luxury housing " MoveInDate="April 2004" Comments="My dream Home"/>
  </Lead>
</BHILeads>
```

```

    <PropertyInterest StateName="TX" MarketName="Austin" BuilderName="David Weekly"
CommunityNumber="Aty666" CommunityName="Staner Ranch" PlanNumber="56433" PlanName="Royal Family"
SpecNumber="24321" SpecAddress="666 Skyway Blvd" Price="360999.00"/>
    <Telemetry CountElements="28" LeadDetails="Buy this home before May, you will get additional bonus"/>
  </Lead>
</BHILeads>

```

Here is an additional sample XML lead file, representing leads from our Spanish-language site CasasNuevasAqui.com.

```

<?xml version="1.0" encoding="UTF-8"?>
<BHILeads>
  <Lead Source="CasasNuevasAqui" LeadType="Community">
    <Contact FirstName="John" LastName="Doe" Email="johndoe@abc.com" Phone="(512) 555-1212 "
StreetAddress="5300 Riata Park Court" City="Austin" State="TX" PostalCode="78727"/>
    <Qualifications Financing="Already selected a lender" MoveInDate="2/2005" Comments="Yo no soy
marinero. Soy capitán."/>
    <PropertyInterest StateName="GA" MarketName="Atlanta" BuilderNumber="2" BuilderName="Pleasant
Valley Homes" CommunityNumber="1111" CommunityName="Sprawling Estates"/>
    <Telemetry CountElements="19"/>
  </Lead>
</BHILeads>

```

#### Appendix: BDXMLLead-v4\_1.xsd (XSD)

```

<?xml version="1.0" encoding="UTF-8"?>
<!-- BDX Lead XML Schema 4.1 -->
<!-- The XML Schema makes full use of the current tab-separated/plain text lead format. We try to keep the XML
leads compatible in content with the text leads, so builders can have the choice of either format, and may acquire
the same amount information. -->
<!-- See Consumer Leads Reporting for details. -->
<xsd:schema xmlns:xsd="http://www.w3.org/2001/XMLSchema" elementFormDefault="qualified"
attributeFormDefault="unqualified">
  <xsd:element name="BHILeads">
    <xsd:annotation>
      <xsd:documentation>This is the containing element of BHILeads</xsd:documentation>
    </xsd:annotation>
    <xsd:complexType>
      <xsd:sequence>
        <xsd:element name="Lead" maxOccurs="unbounded">
          <xsd:annotation>
            <xsd:documentation>Individual lead element</xsd:documentation>
          </xsd:annotation>
          <xsd:complexType>
            <xsd:sequence>
              <xsd:element name="Contact">
                <xsd:annotation>
                  <xsd:documentation>Contact information of the lead
customer</xsd:documentation>
                </xsd:annotation>
                <xsd:complexType>
                  <xsd:attribute name="Title" type="xsd:string" use="optional"/>
                  <xsd:attribute name="FirstName" type="xsd:string" use="optional"/>
                  <xsd:attribute name="LastName" type="xsd:string" use="optional"/>
                  <xsd:attribute name="Email" use="optional">
                    <xsd:simpleType>
                      <xsd:restriction base="xsd:string"/>
                    </xsd:simpleType>
                  </xsd:attribute>
                  <xsd:attribute name="Phone" type="xsd:string" use="optional"/>
                  <xsd:attribute name="StreetAddress" type="xsd:string" use="optional"/>
                  <xsd:attribute name="City" type="xsd:string" use="optional"/>
                </xsd:complexType>
              </xsd:element>
            </xsd:sequence>
          </xsd:complexType>
        </xsd:element>
      </xsd:sequence>
    </xsd:complexType>
  </xsd:element>

```

```

        <xsd:attribute name="State" use="optional">
          <xsd:simpleType>
            <xsd:restriction base="xsd:string">
              <xsd:maxLength value="2"/>
            </xsd:restriction>
          </xsd:simpleType>
        </xsd:attribute>
        <xsd:attribute name="PostalCode" use="optional">
          <xsd:simpleType>
            <xsd:restriction base="xsd:string"/>
          </xsd:simpleType>
        </xsd:attribute>
        <xsd:attribute name="Country" type="xsd:string" use="optional"
default="USA"/>
      </xsd:complexType>
    </xsd:element>
    <xsd:element name="Qualifications" minOccurs="0">
      <xsd:annotation>
        <xsd:documentation>Customer selected assisting
information</xsd:documentation>
      </xsd:annotation>
      <xsd:complexType>
        <xsd:attribute name="PrefPriceLow" type="xsd:int" use="optional"/>
        <xsd:attribute name="PrefPriceHigh" type="xsd:int" use="optional"/>
        <xsd:attribute name="Financing" use="optional">
          <xsd:simpleType>
            <xsd:restriction base="xsd:string"/>
          </xsd:simpleType>
        </xsd:attribute>
        <xsd:attribute name="ReasonsForBuying" use="optional">
          <xsd:simpleType>
            <xsd:restriction base="xsd:string"/>
          </xsd:simpleType>
        </xsd:attribute>
        <xsd:attribute name="MoveInDate" type="xsd:string" use="optional"/>
        <xsd:attribute name="Comments" type="xsd:string" use="optional"/>
      </xsd:complexType>
    </xsd:element>
    <xsd:element name="PropertyInterest">
      <xsd:annotation>
        <xsd:documentation>Home/Community requested by
customer</xsd:documentation>
      </xsd:annotation>
      <xsd:complexType>
        <xsd:attribute name="StateName" type="xsd:string" use="required"/>
        <xsd:attribute name="MarketName" type="xsd:string" use="required"/>
        <xsd:attribute name="BuilderNumber" type="xsd:string" use="optional"/>
        <xsd:attribute name="BuilderName" type="xsd:string" use="required"/>
        <xsd:attribute name="CommunityNumber" type="xsd:string" use="optional"/>
        <xsd:attribute name="CommunityName" type="xsd:string" use="optional"/>
        <xsd:attribute name="MasterCommunity" type="xsd:string" use="optional"/>
        <xsd:attribute name="PlanNumber" type="xsd:string" use="optional"/>
        <xsd:attribute name="PlanName" type="xsd:string" use="optional"/>
        <xsd:attribute name="Options" type="xsd:string" use="optional"/>
        <xsd:attribute name="SpecNumber" type="xsd:string" use="optional"/>
        <xsd:attribute name="SpecAddress" type="xsd:string" use="optional"/>
        <xsd:attribute name="Price" type="xsd:decimal" use="optional"/>
      </xsd:complexType>
    </xsd:element>
    <xsd:element name="Telemetry">
      <xsd:annotation>
        <xsd:documentation>Extended service information</xsd:documentation>
      </xsd:annotation>
      <xsd:complexType>
        <xsd:attribute name="CountElements" type="xsd:int" use="required"/>
        <xsd:attribute name="LeadDetails" type="xsd:string" use="optional"/>
      </xsd:complexType>
    </xsd:element>
  </xsd:sequence>

```

```

        <xsd:attribute name="Source" use="required">
          <xsd:simpleType>
            <xsd:restriction base="xsd:string"/>
          </xsd:simpleType>
        </xsd:attribute>
        <xsd:attribute name="LeadType" use="required">
          <xsd:simpleType>
            <xsd:restriction base="xsd:string">
              <xsd:enumeration value="Rec. Community"/>
              <xsd:enumeration value="Community"/>
              <xsd:enumeration value="Home"/>
              <xsd:enumeration value="BuildOnYourLot"/>
            </xsd:restriction>
          </xsd:simpleType>
        </xsd:attribute>
      </xsd:complexType>
    </xsd:element>
  </xsd:sequence>
</xsd:complexType>
</xsd:element>
<xsd:complexType name="ContactType">
  <xsd:attribute name="Title" use="optional">
    <xsd:simpleType>
      <xsd:restriction base="xsd:string">
        <xsd:maxLength value="50"/>
      </xsd:restriction>
    </xsd:simpleType>
  </xsd:attribute>
  <xsd:attribute name="FirstName" use="optional">
    <xsd:simpleType>
      <xsd:restriction base="xsd:string">
        <xsd:maxLength value="200"/>
      </xsd:restriction>
    </xsd:simpleType>
  </xsd:attribute>
  <xsd:attribute name="LastName" use="optional">
    <xsd:simpleType>
      <xsd:restriction base="xsd:string">
        <xsd:maxLength value="200"/>
      </xsd:restriction>
    </xsd:simpleType>
  </xsd:attribute>
  <xsd:attribute name="Email" use="optional">
    <xsd:simpleType>
      <xsd:restriction base="xsd:string"/>
    </xsd:simpleType>
  </xsd:attribute>
  <xsd:attribute name="Phone" type="xsd:string" use="optional"/>
  <xsd:attribute name="StreetAddress" type="xsd:string" use="optional"/>
  <xsd:attribute name="City" type="xsd:string" use="optional"/>
  <xsd:attribute name="State" use="optional">
    <xsd:simpleType>
      <xsd:restriction base="xsd:string">
        <xsd:length value="2"/>
      </xsd:restriction>
    </xsd:simpleType>
  </xsd:attribute>
  <xsd:attribute name="PostalCode" use="optional">
    <xsd:simpleType>
      <xsd:restriction base="xsd:string">
        <xsd:pattern value="\d{5}(-\d{4})*/>
      </xsd:restriction>
    </xsd:simpleType>
  </xsd:attribute>
  <xsd:attribute name="Country" type="xsd:string" use="optional" default="USA"/>
</xsd:complexType>
<xsd:complexType name="QualificationsType">
  <xsd:attribute name="PrefPriceLow" type="xsd:decimal" use="optional"/>
  <xsd:attribute name="PrefPriceHigh" type="xsd:decimal" use="optional"/>

```



```
<xsd:attribute name="Financing" use="optional">
  <xsd:simpleType>
    <xsd:restriction base="xsd:string"/>
  </xsd:simpleType>
</xsd:attribute>
<xsd:attribute name="ReasonsForBuying" type="xsd:string" use="optional"/>
<xsd:attribute name="MoveInDate" type="xsd:string" use="optional"/>
<xsd:attribute name="Comments" type="xsd:string" use="optional"/>
</xsd:complexType>
<xsd:complexType name="PropertyInterestType">
  <xsd:attribute name="StateName" type="xsd:string" use="required"/>
  <xsd:attribute name="MarketName" type="xsd:string" use="required"/>
  <xsd:attribute name="BuilderNumber" type="xsd:string" use="optional"/>
  <xsd:attribute name="BuilderName" type="xsd:string" use="required"/>
  <xsd:attribute name="CommunityNumber" type="xsd:string" use="optional"/>
  <xsd:attribute name="CommunityName" type="xsd:string" use="optional"/>
  <xsd:attribute name="MasterCommunity" type="xsd:string" use="optional"/>
  <xsd:attribute name="PlanNumber" type="xsd:string" use="optional"/>
  <xsd:attribute name="Options" type="xsd:string" use="optional"/>
  <xsd:attribute name="SpecNumber" type="xsd:string" use="optional"/>
  <xsd:attribute name="SpecAddress" type="xsd:string" use="optional"/>
  <xsd:attribute name="Price" type="xsd:string" use="optional"/>
</xsd:complexType>
<xsd:complexType name="TelemetryType">
  <xsd:attribute name="CountElements" type="xsd:int" use="required"/>
  <xsd:attribute name="LeadDetails" type="xsd:string" use="optional"/>
</xsd:complexType>
</xsd:schema>
```

---

## Change history

DATE	VERSION	NOTES
11/2011	4.1	<ul style="list-style-type: none"> <li>- No new elements added or subtracted. Document reissued to reflect Builders Digital Experience name.</li> <li>- The schema document BDXLead-v4_1.xsd is identical to NHSLead-v4_0.xsd.</li> </ul>
12/2004	4.0	<ul style="list-style-type: none"> <li>- Added discussion of Spanish lead source.</li> <li>- Added Spanish filename conventions.</li> <li>- Edited some documentation for clarity.</li> </ul>
6/2003	3.2	<ul style="list-style-type: none"> <li>- Incremented version to 3.2 to keep in sync with NHS application platform.</li> <li>- Added XML schema to allow corporate reporting of leads in XML format. Only the corporate reporting recipient can accept XML leads.</li> <li>- Added filename convention for TSV file format.</li> </ul>
3/2003	3.1	<ul style="list-style-type: none"> <li>- Incremented version to 3.1 to keep in sync with NHS application platform.</li> <li>- Updated lead recipients; introduced Corporate Reporting Recipient.</li> <li>- Updated delivery schedule notice.</li> <li>- Changed LeadType (column #2): introduced "Rec. Community", deprecated "Market" and "Builder"</li> <li>- Added LeadDetails element (column #39)</li> <li>- Deprecated the following elements (column headers changed to "Unused" to avoid changing previous layout): <ul style="list-style-type: none"> <li>#8 EvePhone</li> <li>#9 BestTimeToCall</li> <li>#18 TimeInMarket</li> <li>#21 NumberInFamily</li> <li>#36 NumberOfBuilders</li> <li>#37 NumberOfRequests</li> </ul> </li> </ul>
10/2001	1.5.2	First publication.

---